

# **Solving Quadratic Equations**

## **By analytic and graphic methods; Including several methods you may never have seen**

Pat Ballew, 2007

I received a copy of an old column in the Mathematics Teacher (March, 1951, pp 193-194) from David Renfro, who writes those wonderful math questions for the people at the ACT, and also regularly takes time out of his busy schedule to educate me about topics I have overlooked, under covered, or just plain done wrong on my math words web page. In this case the column reminded me of the old song, Fifty Ways to Leave Your Lover,

### **50 Ways To Leave Your Lover**

The problem is all inside your head  
She said to me  
The answer is easy if you  
Take it logically  
I'd like to help you in your struggle  
To be free  
There must be fifty ways  
To leave your lover

In this column, however, the logic was applied to solving quadratics, and unfortunately, there are only 18 (ok, I'll add a couple not in the list below, so maybe I will show 20 ways to solve a quadratic equation). I suppose if the song had come out earlier, Professor Hazard, whose letter is a major topic of the column, could have sliced, diced and stretched the existing 18, into a few more, but I think the 18 (plus or minus a few) that are here will serve as a learning experience for most teachers, and almost any student. And speaking of songs, I am reminded of the importance and prestige that comes with

understanding quadratics in yet another song. In Gilbert and Sullivan's operetta *The Pirates of Penzance*, Major General Stanley proudly proclaims to the pirates his knowledge of quadratic equations, among other skills, in "The Major General's Song".

"I am the very model of a modern Major-General, I've information vegetable, animal, and mineral, I know the kings of England, and I quote the fights historical, From Marathon to Waterloo, in order categorical; I'm very well acquainted too with matters mathematical, I understand equations, both the simple and **quadratical**, About binomial theorem I'm teeming with a lot o' news-- With many cheerful facts about the square of the hypotenuse."

I will copy Dave's Note that has part of the column that lists the eighteen ways Professor Hazard presents, and then for each method I'll try to give an example, and a little explanation, a historical note where I think it is helpful, and perhaps an extension where I think it is needed.

### **Dave's Note said**

What follows is part of the Mathematical Miscellanea column edited by Phillip S. Jones in *Mathematics Teacher* 44 #3 (March 1951), pp. 193-194 (pages for this part only, not the entire column)..

A letter from Willian [sic?] J. Hazard of the Department of Engineering Mathematics of the University of Colorado includes the following list of 18 ways to solve  $ax^2 + bx + c = 0$  taken from an article which he published in January 1924 in the 'Colorado Engineer':

1. By factoring by inspection.
2. By factoring after a substitution,  $z = ax$ , which leads to  $z^2 + bz + ac = 0$ .
3. By factoring in pairs by splitting  $bx$  into two terms.

4. By completing the square when  $a$  is 1 and  $b$  is even.
5. By completing the square as usual after dividing through by  $a$ .
6. By completing the square by the Hindu method ("the pulverizer"), i.e. by multiplying through by  $4a$  and adding  $b^2$  to both sides.
7. By completing square as given, adding  $b^2/4a$ .
8. By the formula.
9. By trigonometric methods (see Wentworth-Smith, 'Plane Trigonometry').
10. By slide rule (see Joseph Lipka, 'Graphical and Mechanical Computation'. John Wiley and Sons, Inc. [1918], p. 11 ff.
11. By graphing for real roots. (All modern textbooks.)
12. By graph, extended for complex roots. (See: Howard F. Fehr, "Graphical Representation of Complex Roots," 'Multi-Sensory Aids in the Teaching of Mathematics', 'Eighteenth Yearbook of the National Council of Teachers of mathematics' [1945] pp. 130-138. George A. Yanosik, "Graphical Solutions for Complex Roots of Quadratics, Cubics, and Quartics," 'National Mathematics Magazine', 17 [Jan. 1943], pp. 147-150.)
13. Real roots by Lill circle. (d'Ocagne, 'Calcu graphique et nomographie', from which L. E. Dickson got his reference to it in his 'Elementary Theory of Equations'.) (Also see J. W. A. Young's 'Monographs on, Topics in Modern athematics' "Constructions with Ruler and Compasses.")
14. By extension of the Lill circle to include complex roots.
15. Using the graph of  $y = x^2$  and  $y = -bx - c$  to find real roots. (Lipka, 'op. cit.' p. 26, modifies and extends this solution; Schultze, 'Graphic Algebra'; Hamilton and Kettle, 'Graphs and Imaginaries'.).
16. By extending (15) to include complex roots (Hamilton and Kettle, Schultze).
17. By use of a table of quarter squares. This is a practical method of handling an equation having large constants, as we

already have the table in print (Jones' 'Mathematical Tables').  
18. By use of "Form Factors."

Professor Hazard adds that methods 12, 14, 17, 18 are original with himself, and that 13, 14 and 17 will be discussed in his book 'Algebra Notes' to be published soon.

-----End of article-----

To this list of 18 I will add a 19<sup>th</sup> supposedly created by Newton, that is also a solution for more advanced polynomial equations, and a teaching adaptation of at least one other.

**1. By factoring by inspection...** For most students this is the first method of solving quadratic equations that they learn. I have written (too often say some) that I think this is a pedagogical mistake, and that probably a graphic solution should be first. Vera Sanford points out in her Short History of Mathematics, 1930 that "In view of the present emphasis given to the solution of quadratic equations by factoring, it is interesting to note that this method was not used until Harriot's work of 1631. Even in this case, however, the author ignores the factors that give rise to negative roots." Harriot died in 1621, and like all his books, this one, *Artis Analyticae Praxis ad Aequationes Algebraicas Resolvendas*, was published after his death. An article on Harriot at the Univ of Saint Andrews math history web site says that in his personal writing on solving equations Harriot **did** use both positive and negative solutions, but his editor, Walter Warner, did not present this in his book.

Harriot's method of factoring may look different to what modern students expect. The image shows a clip from David E Smith's 1923 History of Mathematics. Harriot writes out a form for each of the possibilities of  $(a \pm b)(a \pm c)$  with  $a$  being the unknown (where we would use  $x$ ) and then when he needs to factor he picks on one of the forms that match. By separating out the linear coefficient into two parts he is able to break the problem into one of the forms.

Harriot treats of Equations by Factoring. The first important treatment of the solution of quadratic and other equations by factoring is found in Harriot's *Artis Analyticae Praxis* (1631). He takes as his first case the equation

$$aa - ba + ca = + bc$$

and writes it in the form

$$\begin{array}{l} a - b \\ a + c \end{array} \Bigg| = \begin{array}{l} aa - ba \\ + ca - bc, \end{array}$$

also used by al-Khowārizmī and was apparently a favorite problem of the schools. He also considered the arithmetically impossible solutions. For a discussion of his methods and proofs see Woepecke's translation, p. 17; Matthiessen, *Grundsätze*, p. 301.

I would think that examples are not too necessary here. Almost anyone who happens to be reading this has done such a thing. Most readers will probably be able to solve  $x^2 - 5x + 6 = 0$  in their heads by such a method, but I want to do one for the purpose of reminding you how you first learned to think about it.

Many of the oldest quadratics are found in Babylonian clay tablets, and are phrased as sum and product questions; "If the sum of two numbers is 7 and their product is twelve, find the two numbers." The two equations  $a + b = 7$  and  $ab = 12$  can be manipulated so that they become the equation  $x^2 - 7x + 12 = 0$ , yielding the solutions of course, that  $x$  can be either three or four; and since  $a$  and  $b$  are symmetrically interchangeable in the original "sum and difference" problem, these are the values of  $a$  and  $b$ . *[It is interesting that in light of the long history of sum and difference identities in quadratic problems, it was not until Francis Viète (1540-1603) that someone stated the rule that the roots of a quadratic equation  $ax^2 + bx + c = 0$  will sum to  $-b/a$  and have a product of  $c/a$ . It is perhaps a lesson in the power of the algebraic notation that Viète fathered.]*

Turning this around, we now teach introductory algebra students that to find the solution of  $x^2 - bx + c = 0$ , they should try to think of two numbers that add up to  $b$ , and multiply together to make  $c$ , which allow you to write the problem in factored form. (*I still find books that refer to this as "Viète's rule", for instance, Numbers by Heinz-Dieter Ebbinghaus, Hans Hermes, John H. Ewing, K. Lamotke, page 77*)

For the problem above, the factored form is  $(x-4)(x-3) = 0$ . At that point we try to get the student to apply a piece of logic that is, or at least was, referred to as Harriot's Principal, two numbers can only have a product of zero if at least one of them is itself zero. This allows us to state the two conditions under which  $(x-4)(x-3) = 0$ ; either  $x-4 = 0$ , or  $x-3 = 0$ . Solving these two separate conditions (they can NOT both be true at the same time) allows us to state that the equation can be solved when  $x=4$ , or  $x=3$ .

**2. By factoring after a substitution,  $z = ax$** , which leads to  $z^2 + bz + ac = 0$ . According to Boyer's *A History of Mathematics*, this substitution dates back to the Babylonians as well. He gives an example in which the equation  $11x^2 + 7x = 6.25$  (or in the sexagesimal system, it equaled  $6;15$ ) in which the scribe multiplies by 11 so that he can write the problem as  $(11x)^2 + 7(11x) = 68.75$  and solve by completing the square.

Interestingly, I answered a question about this recently on the Math Forum's T2T (Teacher to Teacher) question service by a teacher who had just been introduced to it and wondered how it worked. As so often happens in education, the method had been automated to the point that it was not trivial to understand the substitution that made it work. She referred to it as the "bottom's up method" but I have no idea where that came from. Her method:

$3x^2 + 14x + 8$     Multiply AC, that is  $3 \times 8 = 24$

Now look at B = 14. We are looking for two numbers multiplied together to give 24 and added to give 14. The numbers will be +12 and +2.

$(x + 12)(x + 2)$ --- put the two factors 12 and 2 inside the parentheses, but put x as the first term in both parentheses.

Now, since A was 3, divide the two factors 12 and 2 by 3

$$(x + 12/3)(x + 2/3)$$

This is explained by the substitution  $z = 3x$  (or  $x = z/3$ ) so that substituting into the original equation :

$$\begin{aligned} 3x^2 + 14x + 8 &= 0 \\ \text{becomes } 3(z/3)^2 + 14(z/3) + 8 &= 0 \\ \text{or } z^2/3 + 14z/3 + 8 &= 0 \end{aligned}$$

Now multiplying through by 3 to eliminate the denominators of the fractions gives

$$z^2 + 14z + 24 = 0$$

And we can factor by the sum and product rule we used in Method 1. to get  $(z+12)(z+2)=0$ . Finally we replace z with 3x to restore our original variable and we have  $(3x+12)(3x+2)=0$  and we apply Harriot's Principal to find the solutions.

**3. By factoring in pairs by splitting bx into two terms.** I have seen this called "grouping" in some modern textbooks, and it is often taught as a way of factoring trinomials as much as solving quadratic equations. This uses much the same reasoning as 1. and 2. but a little different approach. If I may reuse the  $3x^2 + 14x + 8=0$  example again; we adapt the rule that we are looking for two numbers that sum to 14 and have a product of 24 (3 x 8). As above, the two values are 12 and 2, so we break 14x up into  $12x + 2x$

and rewrite the equation as  $3x^2 + 2x + 12x + 8$ . Order the terms so that they are grouped so that a common monomial factor can be extracted from the first two (usually an  $x$  or an  $ax$  term) and the last two (only a constant). For this equation we can factor out  $x$  from the first two terms ( $x$ )( $3x+2$ ) and a four from the second pair giving  $4(3x+2)$  and we can rewrite  $3x^2 + 2x + 12x + 8$  as  $x(3x+2) + 4(3x+2)$ . Now by factoring  $3x+2$  from each grouping we get  $(3x+2)(x+4)$ . My personal experience as an educator is that students often find this difficult, seem to think the groupings are arbitrary and frequently become very frustrated. Because of this, and because it does become useful for factoring some different expressions which have nothing to do with solving quadratics, I have introduced a manipulative method to do the same thing that I will call solution 3A)

**3A) By the Magic box..** This is a method based on the multiplication method called "Gelosie" or window multiplication that appears in early arithmetics such as the Treviso arithmetic of the 15<sup>th</sup> century. I introduce them to the method by illustrating an example with multiplication with numbers, then factoring with numbers, and finally I introduce polynomials. Here is an example multiplying two binomials,  $(2x + 3)(4x - 5)$  :

	$2x$	$+3$
$4x$		
$-5$		

For a binomial times a binomial we enter one binomial term by term across the two cells, and one down the left edge. Now we simply multiply the row and column term for each cell:

	$2x$	$+3$
--	------	------



4x	$8x^2$	
-5		

	2x	+3
4x	$8x^2$	12x
-5	-10x	-15

Now we simply combine any like terms  $(12x - 10x) = 2x$  and write the polynomial product as  $8x^2 + 2x - 15$  .

The factoring is a little more difficult, but makes the grouping seem more natural for many students. In this case we have to fill the four cells with the three terms, but that means we have to split the linear coefficient into two parts. Sometimes however, if there are not too many possible factors for the first and last term, you can start with those and let them lead you to the grouping. I use again the example  $3x^2 + 14x + 8$ . We begin by inserting the quadratic and constant term.

	$3x^2$	
		8

At this point we are assisted by the fact that 3 has only a single pair of factors, three and one. So we can add these to the box on either side as the factors, including the x.

	3x	
x	$3x^2$	
		8

Now we need to explore what happens with different factors of 8. Our choices are  $4x^2$  or  $8x^1$ , so we try one (I pick the wrong one for example).

	$3x$	$8$
$x$	$3x^2$	
$1$		$8$

Students need to learn that because the factors  $x$  and  $3x$  are not equal, the box is not symmetric and we need to try  $8$  and  $1$  in both linear positions. If we make the trial multiplications we see that  $3x$  and  $8x$  do not add up to  $14x$ , and if we reverse them, the trial multiplication gives  $25x$  so the choice of  $8$  and one as constants seems to fail. The only other choice was  $4x2$  so we try those

	$3x$	$4$
$x$	$3x^2$	$4x$
$2$	$6x$	$8$

In this set up the two linear terms only add up to  $10x$ , so we need to reverse the  $4$  and  $2$  and try again.

	$3x$	$2$
$x$	$3x^2$	$2x$
$4$	$12x$	$8$

At last, we have found the factors  $(3x+2)(x+4)$ . Students need to be reminded that not everything is factorable, by ANY method, and once in a while in a homework you need to give one that does not work so that students develop the habit of checking all possible methods and experience in recognizing when none of them work.

#### **4. By completing the square when a is 1 and b is even.**

Ahh, this was the method most loved by the ancients, the Greeks, The Babylonians, and the Egyptians, although they seem to have had the basic quadratic formula (#8) as well. I want to show this graphically as well as algebraically. While it must be remembered that they had not yet developed the idea of an equation, the Babylonians began solving problems that are equivalent to solving quadratic equations today perhaps as

early as 1800 BC, and by 400 BC they were using essentially the method we would call completing the square, but negative answers were not considered. Many mathematicians did not accept negatives as a solution until as late as the 17th century, although the Hindu mathematicians of the 7<sup>th</sup> century were working with negative solutions.

As a representative problem, I will use the quadratic  $x^2 + 4x - 21 = 0$ . Earlier mathematicians would have stated the problem in terms of areas, and positive values, so let's think of it as  $x(x+4) = 21$ . This helps to see the picture that would have been visualized by early geometers solving the problem, a rectangle with one side of length  $x$ , and another four units longer,  $x+4$ . The total area of the rectangle would be 21 square units, but we will often ignore the units from here on.

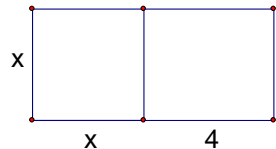

From the image it is easy to see the squares of area  $x^2$  and a rectangle with area  $4x$ , and together they will have the given area of 21 square units. The geometric method was to divide the  $4$  by  $x$  rectangle into two

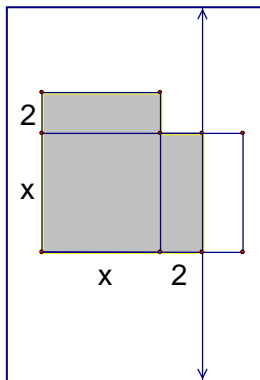

equal  $2$  by  $x$  rectangles, and then fit one on each side of the  $x^2$  square. It was this idea of dividing the area into two parts that, I think, prompted the use when the linear term was even. The area of 21 now consists of a square that is  $x$  on each side, or  $x^2$ , plus two rectangles that are  $2x$  each, for a total of  $x^2 + 2x + 2x$ . Now the shaded portion looks almost like a square, except for a piece missing on the corner. It is the filling in of this small

piece that gives the method its name; we will need to add another small area in order to "complete the square." From the picture it should be obvious that the "missing" corner is a  $2 \times 2$  square, and so when we add this square to "complete" the square, we have added to the total

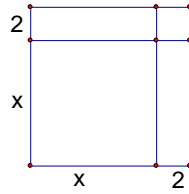

area, increasing it from 21 to 25 square units. We now have a perfect square, so that each side, or the square root, is  $x+2$ .

Since we know that  $(x+2)^2$  is the same quantity as 25, we only have to solve by taking square roots of both sides to get the two possible solution cases, either  $x+2 = 5$ , or  $x+2 = -5$ . From these we get the solution;  $x$  may either be 3 or  $-7$ .

### 5. By completing the square as usual after dividing through by a.

Ok, this is just taking an equation that has a quadratic coefficient other than one and dividing to make it the same as method 4. A problem like  $2x^2 - 3x + 5 = 0$ , for example could be rewritten as  $x^2 - 1\frac{1}{2}x + 2\frac{1}{2} = 0$ .

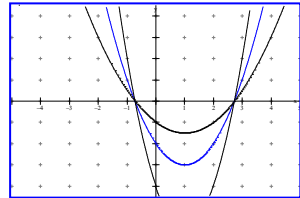

It is not at all trivial, I think, to most students that we can arbitrarily

multiply or divide every term of an equation without changing the solution values. I think this is a very good reason to make sure that in teaching the evaluation and solution of quadratics we tie them closely to graphing. This allows a visual image of what happens when an expression is multiplied (or divided) by a non-zero constant, and more specifically, what happens in that special case where the function value is zero. The graph shows a function,  $f(x) = x^2 - 2x - 2$  and the same function multiplied by two, and also divided by two.

If a student has a good grasp of graphing, then a graphic solution is the easiest way to factor almost any polynomial, especially in the age of graphing calculators. I may not recognize at a glance the factors of  $6x^2 - x - 15$ , but a quick glance at the graph and I suspect that the only rational roots near these intersections are at  $-3/2$  and at  $+5/3$ . If these are indeed the roots, then working backwards from Harriot's principle we get



that  $(x + 3/2)=0$  or  $(x-5/3)=0$ . Multiplying by the denominator in each case gives us  $(2x+3)$  and  $(3x-5)$  as the factors.

**6. By completing the square by the Hindu method ("the pulverizer"), i.e. by multiplying through by  $4a$  and adding  $b^2$  to both sides.**

The same Dave Renfro who sent me the magazine article that prompted my present writings has also written a really nice article on this particular method which will (or has, depending on when you read this) appear in the *Mathematical Gazette* in July of 2007. I will lean heavily on Dave's research here, but assure you the paper is a good read with lots of detail that I have not included here.

The method seems to have been created in the 9<sup>th</sup> century by a Hindu (in the 19<sup>th</sup> century the English seemed to use the spelling Hindoo) named Sridhara. The period in which he lived seems somewhat in dispute, but it must have been as early as the 9<sup>th</sup> century by virtue of the known writers who quoted him shortly afterward. In spite of its early creation, I cannot find much evidence of its use prior to around 1815 in western mathematics. The method and the attribution as the "hindoo method" seems to have come from a translation by Edward Strachey of a Hindu paper called the *Bija Ganita* in 1813. Here is a quote from the *Historical and descriptive account of British India*, By Hugh Murray, and others.

"In the year 1813, Edward Strachey of the East India Company's service published a translation from the Persian of the *Bija Ganita* (or the *Vija Ganita*), a hindoo work on algebra written by Bhascara Acharya, who lived about the year 1150, of the Christian era...

The more common spelling today is Bhaskara. The *Bija Ganita* was translated into Persian in 1634, and Strachey's

translation was from the Persian into English. I believe it is in this translation that the method of Sridhara, which was so often called the Hindoo method, seems to have made its way to the west.

One of the things that made it popular was that it avoided the use of fractions. This was achieved by multiplying through by a constant equal to four times the original quadratic coefficient. I will use the example  $3x^2 + 14x + 8 = 0$  to illustrate this example also. As in most completing the square methods, we first remove the constant term to the other side of the equation;  $3x^2 + 14x = -8$ . Next we multiply through each term by the constant  $4A$ , or in this case 12, to get  $36x^2 + 168x = -96$ . Note the price of no fractions is often large values of the other terms, but nothing more than a simple square root is needed, so they really will not pose a problem. The final step in completing the square is to add  $b^2$  to both sides. In this equation  $b=14$  so we need to add  $14^2$  or 196 to each side to give us  $36x^2 + 168x + 196 = -96 + 196$ . By using this process we have now made a perfect square trinomial on the left side of the equation, the square of  $(6x + 14)$ . The process is even simpler than it may first appear because it will always be  $(2A + B)$ . A moment of your time would be well spent in confirming that the middle term,  $168x$ , is indeed twice the product of  $6x$  and  $14$ .

At this point we have  $(6x+14)^2 = 100$ , and the two possible solutions are  $6x+14 = 10$  or  $6x+14 = -10$ . The simple algebra gives us  $x=-4$ , and  $x=-2/3$  as the solutions.

Before I close on this topic I wanted to make a brief note about Professor Hazard's use of the term "Pulverizer" in relation to this method. I have never seen that term used for this method. The Arabic translations of the Lilavati of Bhaskara used a method of finding common divisors and solving Diophantine problems by a method that is essentially what we might call Horner's Rule. The term in the Arabic for this was *kuttaka*, to pulverize. I have seen this method, used to

produce continued fractions, referred to as the "Pulverizer", and in some early Algebras of the middle ages, it seems that the term was used to describe the method we might today call Algebra. *kuṭṭaka*, is a Sanskrit term, also given as: kuṭṭa, which literally means "breaking, bruising" (from the verbal root: kuṭṭ-, to crush, to grind, and also: to multiply), or when used as a substantive it means: pulveriser, multiplier. Brahmagupta was apparently the first who wrote a treatise about it. A mention of the term is contained in a foot note of *A History of Civilization in Ancient India, Based on Sanscrit Literature*, by Romesh Chunder (Rabindra Chandra ) Dutt in 1890.

\* A striking history has been told of the problem, to find  $x$  so that  $ax^2 + b$  shall be a square number. Fermat made some progress towards solving this ancient problem, and sent it as a defiance to the English algebraists in the 17th century. Euler finally solved it, and arrived exactly at the point attained by Bhāskara in 1150 ! A particular solution of another problem given by Bhāskara is exactly the same as was discovered in Europe by Lord Brounker in 1657 ; and the general solution of the same problem given by Brahmagupta in the 7th century A. D. was unsuccessfully attempted by Euler, and was only accomplished by De la Grange in 1767 A. D. The favorite process of the Hindus known as the *Kuṭṭaka* was not known in Europe till published by Bachet de Mezeriac in 1624 A. D.

As I was writing this section I had the good fortune to have a visit from an excellent professor of Sanskrit language, Karel van Kooij, who helped me understand the meaning of some of the Arabic terms, such as Kuttaka and Bijaganita. The literal translation of Bijaganita, is calculation (ganita) of primary causes (bīja). It is also a Sanskrit term for "analysis, or algebra". It was also the name of the second part of Bhāskara's Siddhāntaśiromani, a major work on astronomy. This book has four divisions. The first was

called The Līlavatī with a literal translation that meant "full of beauty or charming". This section was on arithmetic, algebra, and simple geometry. The second section was the Bijaganita, which is explained above, and was apparently the section translated by Strachey. Part three was called The Ganitādhyāya, literally "the chapter on arithmetic" and part four was The Golādhyāya which means "the chapter on globes". This was a section on astronomy and the "globes" are of the earth and celestial globes such as the sun and the planets.

**7. By completing square as given, adding  $b^2/4a$ .** If you were to ignore the geometric foundation, we can see that any partial quadratic expression  $ax^2+bx$  can be converted to a perfect square trinomial if we simply add an appropriate constant,  $c$ , for a third term. And if it is a perfect square trinomial, then it must be that the first term of the trinomial is the square root of  $ax^2$ , or  $\sqrt{a} x$ . The product of twice the square root of this term,  $\sqrt{c}$ , and the constant term must be the middle, or linear, term, ie  $2\sqrt{a} \sqrt{c}$  must equal  $b$ . We can then, solve for  $c$  to find the needed constant term needed complete the square. It turns out that the value would

be  $\frac{b^2}{4a}$ . This allows us to solve  $3x^2 + 14x = -8$  by adding

$\frac{14^2}{4(3)} = \frac{49}{3}$  on both sides of the equation to complete the

square on the left side.  $3x^2 + 14x + 49/3 = 49/3 - 8$ . The perfect square on the left allows us to write the equation as  $(\sqrt{3} x + 7/\sqrt{3})^2 = 25/3$ . We proceed by taking square roots of both sides (keeping in mind that there may be both a positive and negative value for  $(\sqrt{3} x + 7/\sqrt{3})$  and we have  $\sqrt{3}$



$x + 7/\sqrt{3} = 5/\sqrt{3}$  for one solution and  $\sqrt{3}x + 7/\sqrt{3} = -5/\sqrt{3}$  for the other. Solving for  $x$  we get, and simplifying the result gives us the same  $x = -2/3$  and  $x = -4$  as before. I think it is probably the number of irrational terms popping up through the expression that made it unlikely to be a favorite of teachers or students, and I seldom find it in old texts.

### 8. By the formula.

By far the most common method shown in old texts (and many new ones) is the "quadratic formula". Interestingly, it may be the oldest form of solution. The earliest history of quadratic equations is by the Babylonians as early as 400 BC. The web site on math history at St. Andrews University says, "To solve a quadratic equation the Babylonians essentially used the standard formula. They considered two types of quadratic equation, namely

$$x^2 + bx = c \text{ and } x^2 - bx = c$$

where here  $b, c$  were positive but not necessarily integers. The form that their solutions took was, respectively

$$x = \sqrt{[(b/2)^2 + c]} - (b/2) \text{ and } x = \sqrt{[(b/2)^2 + c]} + (b/2).$$

Many of the problems concerned the area of rectangles. They include a sample problem from a Babylonian clay tablet gives the area of a rectangle as 60 and a difference in length and width of 7. The equation, then, would be  $x^2 + 7x = 60$ . But they had no way to express equations. To find the answer the scribe directs the reader to find half of 7 and square it to get  $12 \frac{1}{4}$ . then add 60 to get  $72 \frac{1}{4}$ . Take the square root (they would have a table of squares to do this) to get  $8 \frac{1}{2}$ .

Finally, subtract  $3\frac{1}{2}$  (half of the 7) to get 5 for the width of the rectangle. This is essentially the method that appeared in high school text until the 1900's (perhaps later) under the directions "to solve  $x^2 + bx = c$ ; use  $x = \sqrt{[(b/2)^2 + c]} - (b/2)$ ".

Many old texts present the quadratic formula, in a single form, or several variations; without proof as an object to be memorized. I assume in one hundred years teachers will look back and think far too much mindless memory work occurs in modern classrooms, but one hundred years ago it was assumed that a student who worked with mathematics would commit to memory a wide range of formula and algorithms. As an example, here was a poem that was provided to help students memorize the method of taking square roots. Teachers might want to assign this to the next student who complains that they cannot memorize the sine and cosine of  $30^\circ$ ,  $45^\circ$ , and  $60^\circ$  angles.

A Rule to be got by heart,

*The Root of your first Period you  
Must place in Quote, if you work true :  
Whose Square from your said Period then  
You must subtract ; and to it's Remain  
Another Period being brought,  
You must divide as here is taught ;  
By the Double of your Quote, but see  
Your Unit's Place you do leave free ;  
Which Place will be supply'd by it's Square  
Of your next quoted Figure there :  
Next multiply, subtract, and then  
Repeat your Work unto the End ;  
And if your Number be irrational,  
Add Pairs of Cyphers for a Decimal,*

The poem appeared in the 1772 textbook, *Arithmetick, both in the theory and practice : made plain and easy in all the common and useful rules*, by John Hill.

Even a great mathematician like Euler, after deriving the formula, suggests "it will be proper to commit it to memory". Here is an image from *An Introduction to the Elements of Algebra* (page 191) by Euler from the translation by John Farrar

in 1821. Euler (Farrar?) writes his quadratic as  $x^2+px=q$ . Notice that he uses the  $b^2/(4a)$  rule from the previous method, but with the a term reduced to 1, so that the added value is  $\frac{1}{4} p^2$ .

559. This formula contains the rule by which all quadratic equations may be resolved, and it will be proper to commit it to memory, that it may not be necessary to repeat, every time, the whole operation which we have gone through. We may always arrange the equation, in such a manner, that the pure square  $x x$  may be found on one side, and the above equation have the form  $x x + p x = q$ , where we see immediately that

$$x = -\frac{1}{2}p \pm \sqrt{\frac{1}{4}p^2 + q}.$$

For the modern student, the quadratic formula is usually written as  $ax^2 + bx + c = 0$  and the solution is given as

$$x = \frac{-b \pm \sqrt{b^2 - 4ac}}{2a}$$

The solution for  $3x^2 + 14x + 8 = 0$  would then

be  $x = \frac{-14 \pm \sqrt{14^2 - 4(3)(8)}}{6}$ . This simplifies to the  $(-$

$14 \pm 10) / 6$  which gives the same values as previously,  $-4$  and  $-2/3$ .

I found a web page by Don Allen at Texas A&M university that suggested that the early origin of the formula may have been due to a misunderstanding. Here it is:

## A possible origin of quadratic equations and solutions

It has been conjectured by some authors, notably N. Katz, *A History of Mathematics*, that the origin of the quadratic

formula may have resulted from the confusion between the knowing the perimeter and knowing the area of a rectangular region. Here is how the argument unfolds.

Suppose we know the perimeter of a rectangle to be  $P = 2p$ .

Thus  $p$  is the sum of the length and width. What is the area?

Well, the two sides  $x$  and  $y$  can be written as

$$x = \frac{p}{2} + d$$

$$y = \frac{p}{2} - d$$

Thus the area is

$$q = xy = \left(\frac{p}{2} + d\right)\left(\frac{p}{2} - d\right) = \frac{p^2}{4} - d^2$$

Solving we obtain

$$d^2 = \frac{p^2}{4} - q$$

$$d = \sqrt{\frac{p^2}{4} - q}$$

This gives

$$x = \frac{p}{2} + \sqrt{\frac{p^2}{4} - q}$$

$$y = \frac{p}{2} - \sqrt{\frac{p^2}{4} - q}$$

This is the form of the solution of the quadratic equation

$$x^2 + q = px,$$

If it was the case that some people believe the area depended only on the perimeter, this gives a method of finding a variety of rectangles having the same perimeter but different areas. It is just conjecture, but one with a reasonable plausibility. In any event, the necessity of solving quadratics can arise from simple area calculations.

**9. By trigonometric methods (see Wentworth-Smith, 'Plane Trigonometry').** For the student of today who crunches wild numbers on a calculator, the trigonometric method might seem a long way to a solution. The student of a century ago had no such labor saving device packed in his book-bag, and solutions of quadratics involving decimals to even modest length was very tedious. Two of the labor saving devices that were often available to the students a century ago were a table of trigonometric values, and one of their logarithms. These two tools made the following trigonometry methods "shortcuts" for some problems. The method presented in the book by Wentworth and Smith referenced by Professor Hazard in the original article does not, in my view, give a very nice explanation of how and why the trigonometric method works, so I will use a slightly more general approach.

The method works best if we separate quadratics into two types, those in which the c term is positive, and those in which it is negative. The method involves two rather unusual

identities. The first is  $\tan^2\left(\frac{\theta}{2}\right) - \frac{2}{\sin(\theta)} \tan\left(\frac{\theta}{2}\right) + 1 = 0$  This is

the form we use if the constant term is positive. For the case of a negative constant the identity would be

$\tan^2\left(\frac{\theta}{2}\right) + \frac{2}{\tan(\theta)} \tan\left(\frac{\theta}{2}\right) - 1 = 0$ . The question of course, is how

we apply this to the solution of a quadratic equation?

We will use the equation  $x^2 - 7x + 12 = 0$  for a run through to illustrate the trigonometric method. We condition the equation by making the substitution  $x=z\sqrt{c}$  and simplifying. In our present case, we get  $x=z\sqrt{12}$  so the equation becomes  $12z^2 - 7\sqrt{12}z + 12=0$ ; and dividing all terms by 12 gives us the equation  $z^2 - (7/\sqrt{12})z + 1=0$ , a look alike for our first trigonometric identity with  $z=\tan(\theta/2)$  and  $2/\sin(\theta) = 7/\sqrt{12}$ . To find the solution we first simplify  $2/\sin(\theta) = 7/\sqrt{12}$  to  $\sin(\theta)=2\sqrt{12}/7$ . This has two solutions in the interval  $0^\circ$  to  $360^\circ$ , one at  $81.79^\circ$ , and the supplement of that,  $98.213^\circ$ . Since  $z=\tan(\theta/2)$  we can find  $z = .866$  from the first angle (tell me you are thinking  $\frac{1}{2}$  the square root of three), and  $z= 1.155$  from the second(a little harder to recognize, it is the reciprocal of the other value of  $z$ ). Now using the substitution  $x= z\sqrt{12}$  we get  $x=3$ , for one solution and  $x=4$  for the other. The quadratic that was used for the example in the Wentworth Smith book was  $x^2+ 1.1102x - 3.3594=0$ . You might want to run through it once without your calculator to appreciate why the earlier math student might have wanted an alternative. NO?

To take this method to an extreme, the story is told that when Francios Viète was challenged to solve a  $45^{\text{th}}$  degree polynomial equation. He recognized the coefficients as the expansion of  $2 \sin(x)$  in terms of  $2 \sin(x/45)$ , an area of trigonometry he had developed by the use of his new "*logistica Speciosa*".

**10. By slide rule** For a generation of students who have never seen a slide rule, this method may hold some interest primarily for the insight into the many things that could be done with the simple instrument. I include a picture below of what one looks like, set to solve the quadratic equation  $x^2 - 7x + 12 = 0$ . (students interested in exploring a little more may find a virtual slide rule online at

<http://www.antiquark.com/sliderule/sim/n909es/virtual-n909-es.html>) .

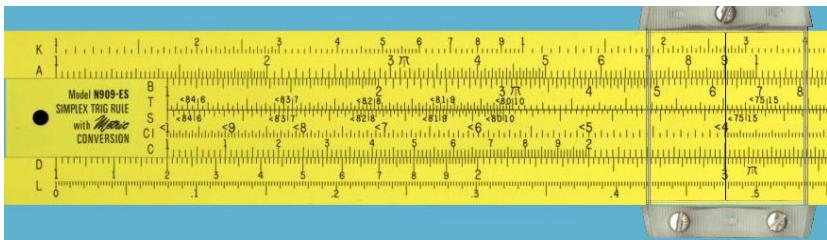

Recalling the idea that the sum of the two solutions of a quadratic was the opposite of the  $b$  term, and the product was the constant term, we align the index (1) on the C-scale with the 12 on the D scale. The numbers on the C and D scale are now in a constant ratio, for example the 2 on the C scale is aligned over the line representing 24 on the D scale etc. This is the method that was used for division; the quotient of any number on the D scale divided by 12 can be read off on the C scale. But what we need is a table of numbers that multiply together to make 12. With such a table we could just scroll down the list until we found the two that add up to 7, and we would have our solution. The values on the CI scale, are the reciprocals of the C scale, and so the CI and D scales together provide just such a table. Any two numbers aligned on the CI and D scales have a constant product of 12. You might check and notice that the 2 on the D scale is under the 6 on the CI scale, for example, but 6 and 2 do not add up to 7, so we keep looking and a little farther to the right under the sliding cursor hairline, we see that 3 and 4 are aligned also, and we recognize our solution.

The slide rule, like early calculators, had no decimal points, so the line representing 12 would also represent 1.2 and 120 for example. It was the students' honor, and responsibility, to keep track of the decimal point in operations.

It is of historical interest that the slide rule, which was invented by 1621, did not become popular in schools until late in the 19<sup>th</sup> or early in the 20<sup>th</sup> century. The little sliding cursor that seems to be such an essential part was not added until

1856, although Cajori suggests that Newton must have used such a device to use the method I will cover next.

**10b. Newton's method of solving algebraic equations on logarithmic lines.** In Cajori's *The Slide Rule*, 1909 he translates a letter from Oldenburg to Leibnitz, dated June 24, 1675 :

"Mr. Newton, with the help of logarithms graduated upon scales by placing them parallel at equal distances or with the help of concentric circles graduated in the same way, finds the roots of equations. Three rules suffice for cubics, four for biquadratics. In the arrangement of these rules, all the respective coefficients lie in the same straight line. From a point of which line, as far removed from the first rule as the graduated scales are from one another, in turn, a straight line is drawn over them, so as to agree with the conditions conforming with the nature of the equation; in one of these rules is given the pure power of the required root."

Newton then, must have been able to solve a quadratic by the use of logarithmic lines. For a quadratic, only two rules are needed, and although I have never seen the method, I presume it must work something like this. To solve  $x^2+3x=10$ , we will align the two logarithmic rules so that the linear term, 3 is above the 1 on the second rule. As far above the first rule as the two are from each other, place the endpoint of a ray. Rotate the ray until the two values where it intersects the two rules equal the constant term, 10. The positive solution is shown on the ray that passes through 6 on the top scale and 4 on the lower  $(6+4)=10$ . The solution is 2, the square root of 4. Notice that this works because as the angle opens, the distance on the upper scale is the log of  $x$  and the lower scale will be, by similar triangles, half as far, so it is  $x^2$ . By starting



at the point 3, all the values where the line crosses the top scale are values of  $3x$ , and the values of the lower scale are  $x^2$ , and we need a ray such that  $3x + x^2$  will equal 10.

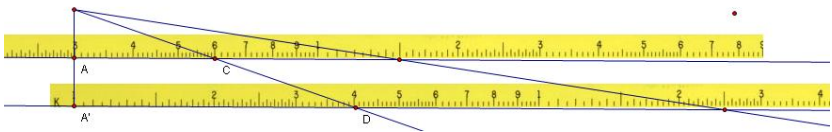

There is also a negative solution, shown by the second line passing through 15 and 25 because  $-15 + 25 = 10$  also. The square root of 25 is 5 and so the second solution is -5.

Newton, at least according to Oldenburg's letter, could add additional rules and solve third and fourth power equations.

Any method that solves quadratic equations must also find square roots, and simply lining up the two index ones on the cursors does this.

Here the square root of eight, on the lower rule, is read off on the upper rule as (approximately) 2.8.

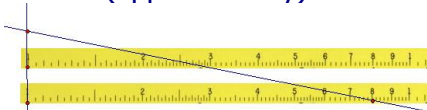
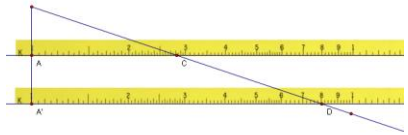

**11. By graphing for real roots. (All modern textbooks.)** I

find the professors parenthetical enclosure somewhat curious. I assume as a professor of engineering at a university, he must mean college texts of the time, because it was not, at the time of the column being printed (1951) common to see graphing in all high school algebra texts. I have a note posted by the recently deceased math historian Karen Dee Michalowicz commented on the history of graphing in education "It is interesting to note that the coordinate geometry that Decartes introduced in the 1600's did not appear in textbooks in the context of graphing equations until much later. In fact, I find

it appearing in the mid 1800's in my old college texts in Analytical Geometry. It isn't until the first decade of the 20th century that graphing appears in standard high school algebra texts. Graphing is most often found in books by Wentworth. Even so, the texts written in the 20th century, perhaps until the 1960's, did not all have graphing. Taking Algebra 1 in the middle 1950's, I did not learn to graph until I took Algebra II."

Even then I think it was not common to see graphing used as method of solving quadratic equations. Curious about the use of graphing as a solution, I did a search and found a copy of former Education Secretary William Bennett's *James Madison Elementary School, A Curriculum for American Students*, 1988. It is for elementary school, but the program proceeds to eighth grade and includes, for the Algebra One course,

*Algebra.* Students solve quadratic equations by factoring, completing the square, and applying the quadratic formula, and they use substitution and matrices to solve systems of linear equations. Algebraic modeling is used to explore problems of exponential growth and decay. In context of the Cartesian plane, students learn ideas about functions, absolute value, range, and domain; interpret graphs and their relations to corresponding equations; and analyze the effects of parameter changes on graphs of functions. Story problems relate quadratic and linear equations to geometric concepts. Problems in logic are solved using Venn diagrams.

Ok, you can make a (weak, in my mind) defense for graphic solutions from the phrase "interpret graphs and their relations to corresponding equations", but it is not bold and deliberate like "Students solve quadratic equations by ....". I would think that in the age of ubiquitous graphing calculators, it would be the most common method taught. With a good graphing calculator you can teach a kid to solve a linear equation by graphing, then do the same with a quadratic, and I'm betting most students can not only solve a cubic, but a large number will solve  $\ln(x)-2=0$  even if they are not sure what  $\ln(x)$  means. But the column was not printed in an age of graphing

calculators, and even after 37 years when Secretary Bennett wrote his paper, they were just beginning to be common in classrooms.

The algebra II textbook presently used in my school (2007) does illustrate solving quadratics by graphing, but only with a single page example in a "technology tip" that shows how to solve using the graphing sub-functions on a ti-83 calculator.

For the typical 1951 student, and the calculator blessed student of today, the method to solve by graphing requires two things; the ability to produce a graph of  $y = f(x)$  for a quadratic function, and the recognition that when  $f(x) = 0$ ,  $x$  is a solution to the quadratic equation. The former is much easier with the calculator, and the experience, if it is as valuable as it should be, will make the student more able to do the second.

Here I have graphed the function  $y = x^2 - 7x + 12$  in order to solve the quadratic  $x^2 - 7x + 12 = 0$ . The two solutions show up as the values on the x-axis. For the student of earlier years, the graph would need to be plotted on fine grid paper perhaps 1mm grid, so that the calculations would give a decent value for the solutions if they were not integers.

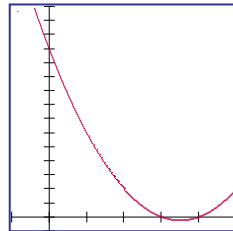

One of the nice things about the graphic method is that it allows the student to see that the two roots are always equally spaced from the axis of symmetry, a vertical line through the vertex of the parabola. A little planned exploration and they realize that this is the  $-b/2a$  that they have encountered so often in the quadratic formula. It also gives a nice application of using the vertex formula of the function. Any quadratic graph  $y = ax^2 + bx + c$  can also be written in the form  $y = a(x-h)^2 + k$ , where the values of  $h$ , and  $k$  represent the  $x$ , and  $y$ , coordinates of the vertex of the parabola. In the case of the equation  $y = x^2 - 7x + 12$  we can rewrite it as  $y = (x -$

$\frac{7}{2})^2 - \frac{1}{4}$ . To show how this can be helpful, I will use a graphic approach, which does not need more than a simple rough sketch to solve  $3x^2 + 14x + 8 = 0$ . We begin by finding the axis of symmetry, using  $-b/2a$  with  $b=14$  and  $a=3$ . The axis of symmetry is the line  $x=-14/6$ , or  $-7/3$ . This is also the value of the x-coordinate of the vertex, so we can find the y-coordinate by evaluating the expression when  $x = -7/3$ .  $3(\frac{7}{3})^2 + 14(\frac{-7}{3}) + 12 = \frac{-25}{3}$ , so the vertex of the graph is at  $(\frac{-7}{3}, \frac{-25}{3})$ . Since the first term is positive, we know the graph curves up from the vertex, and so it must cross the x-axis in two places, the two real solutions. One of those things that should come across in learning to graph quadratics is that the pattern from the vertex is always the same. If you move right or left (a change in the x direction) any distance from the vertex, the y value will change an amount equal to the square of the x-change times the a-coefficient. For example, if we move one to the right (or left) of the vertex on this graph, the y value will increase 3 ( $1^2$ ) or three units. We could then plot the values  $(\frac{-4}{3}, \frac{-16}{3})$  and  $(\frac{-10}{3}, \frac{-16}{3})$ .

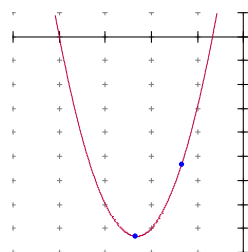

So how does this help us solve the quadratic? Since the vertex is  $\frac{25}{3}$  below the x-axis, our two intercepts will be found when we go to the right and left far enough that the curve will rise  $\frac{25}{3}$  units; thus we can find the x change needed by solving  $3x^2 = \frac{25}{3}$ . This distance,  $\frac{5}{3}$ , to the right and left of the axis of symmetry will give a solution, one at  $-\frac{7}{3} - \frac{5}{3}$ , or  $-4$ ; the other at  $-\frac{7}{3} + \frac{5}{3}$ , or  $-\frac{2}{3}$ .

**12. By graph, extended for complex roots.** One of the nice things a graphing calculator does is allow the student to look at lots of graphs quickly. I'm sure most of my students produce more graphs in a single semester than I graphed in my entire high school experience. A student who has been

trained to understand that the (*real*) solutions of a quadratic are the x-intercept values quickly understands that there are no real solutions to  $x^2 - 2x + 5 = 0$ . The graph of  $y = x^2 - 2x + 5$ , at right makes that clear by not crossing the x-axis at all. But there are several methods to use the graph to visualize the complex solutions of the equation once a student has been introduced to complex numbers.



After they have found the complex solutions by completing the square or the quadratic formula, and realize that the real part of the solution is the x-value of the axis of symmetry,  $x = -b/2a = 1$ , we can show them a simple three step method. First, reflect the curve in the horizontal line through the vertex. Next find the distance from the axis of symmetry,  $x = -b/2a = 1$ , to the x-intercepts of the reflected graph, in this case, 2 units. This distance is the value of the imaginary coefficient, and the solutions are  $x = 1 + 2i$  and  $x = 1 - 2i$ . The solutions may be presented in their proper Argand diagram locations by taking the line segment joining the two imaginary solutions, and rotating it  $90^\circ$ .



The solutions can also be found by using the hand graphing idea at the end of the real solutions graphing section. Since the graph has a vertex that is four units too high to intersect the x-axis, we need a change in x from the axis of symmetry so that  $x^2 = -4$ , and that distance is a positive or negative 2i.

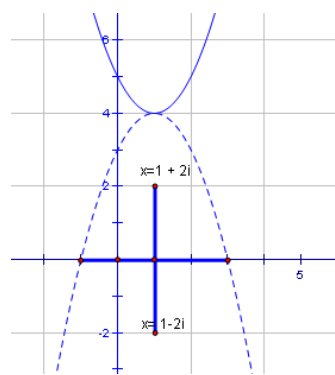

**13. Real roots by Lill circle.** One of the most unusual graphic methods I have ever seen comes from a more general

method of solving algebraic equations first proposed, to my knowledge, by M.E. Lill, in *Resolution graphique des équations numériques de tous les degrés...*, *Nouv. Ann. Math. Ser. 2* **6** (1867) 359--362. Lill was supposedly an Artillery Captain, but his method was included in *Calcul graphique et nomographie* by a more famous French engineer, Maurice d'Ocagne, who called it the "Lill Circle". Some years later the method made its way into English in a book by Leonard E. Dickson, *Elementary Theory of Equations..* [or maybe not.... Professor Dan Kalman from American University in Washington, D.C. wrote to tell me of his research on the history of this problem:

"There is a solution of the quadratic in the copy of Dickson I have, on his page 16, virtually identical to the solution give in the article shown in the attached PDF file [L. E. Dickson; W. W. Landis; B. F. Finkel; A. H. Holmes; L. Leland Locke; G. B. M. Zerr; *The American Mathematical Monthly*, Vol. 11, No. 4. (Apr., 1904), pp. 93-95.]. That latter is from a problem Dickson proposed to the Monthly, in 1904, 10 years before the first edition of elementary theory of equations in 1914. In the monthly article, credit is given to Lill via d'Ocagne, but in the book there is no mention of Lill. I suppose it is possible that Dickson went back and put in a credit to Lill in a later edition. It seems strange since he clearly knew about the credit when the first edition of his book was published, but how else can you account for various secondary or tertiary accounts of Dickson giving the credit to Lill?" *Anyone???*]

Dickson studied with Jordan in Paris between 1895 and 1899 and may well have been exposed to the method during that period.

I found a note about an earlier English translation in *The American Mathematical Monthly*, Vol. 29, No. 9 (Oct., 1922), pp. 344-346 by W.H. Bixby in a discussion about an article on "Graphical Solution of Numerical Equations." "...the method of Mr. Lill, Austrian engineer, developed by him about 1867 and exhibited by him at the Vienna World Exposition a little later, is the best graphical method yet developed, and far easier, quicker, and more exact, than any other graphical method. I read of this about 1878 and published it in 1879 by a privately printed pamphlet. At that date I had not seen Lill's 1867 printer article. A few months ago I found that Luigi Cremona had also described Lill's method and made it public to English readers in 1888." Mr. Bixby's pamphlet, for those who might seek it out, is titled *Graphical Method for Finding the Real Roots of Numerical Equations of Any Degree if Containing but One Variable*, and was published in West Point in 1879. [Dan Kalman came to my rescue again with two pamphlets . Here is his message and a link to the two documents:

"I found two pamphlets by Bixby in the Martin Collection. I made electronic versions of copies, but one of those is so large that I hesitate to put it in email. Instead, I posted it on the internet. You will find Bixby's pamphlet [here](#) ]

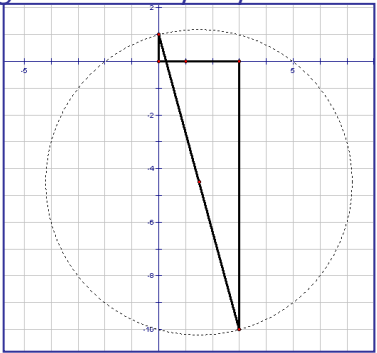

-----

The method involves laying out sequentially perpendicular segments with lengths equal to the a, b, and c coefficients. I have not seen Lill's original article, and so this is the method, as I know it. I will use the equation  $x^2 - 3x - 10 =$

0 again. The first segment, of length one is drawn from the point on the y-axis at  $(0,1)$  down to the origin. (a note about equations when the first coefficient is NOT one will be given in a little later) . Perpendicularly along the x-axis from the origin a segment of length equal to  $b$  is drawn so that it goes to the point  $(-b,0)$ . The choice of  $-b$  just allows the solution to lie on the correctly signed points along the x-axis. One example I saw reversed the direction for both the  $a$  and the  $c$  segments as well. From this point a line is drawn vertically from  $(-b,0)$  to  $(-b,c)$  . A segment is then drawn from  $(0,1)$  to  $(-b,c)$ . This segment serves as a diameter for a circle to be constructed, and the solutions of the equation are the points where this circle intersects the x-axis. For our example,  $x^2 - 3x - 10 = 0$ , we will draw the  $b$  segment 3 units to the right of the origin and the  $c$  segment ten units downward from the point  $(3,0)$ . The circle intersects at the proper solution of  $x=5$ , and  $x=-2$ .

If the method is used for an equation that has an  $x$  term not equal to one, the value of the solutions must be adjusted by dividing

by the coefficient of  $a$ . For an example, I have used the equation  $3x^2 + 14x + 8 = 0$ . Notice that the circle intersects at  $x = -2$  and  $x = -12$ . Dividing the intersections by the  $a$  coefficient, 3, gives the solutions  $-2/3$ , and  $-12/3 = -4$ . A student, or teacher, can develop a much better feel for the relationship between the values of  $b$ , and  $c$ , and the solutions by playing with Lill circle sketches of various equations.

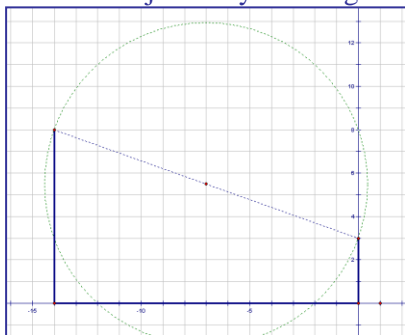

In a later communication with Professor Kalman, he explained that he had discovered that the right angles were not essential to the method, and the lattice could intersect at any angle for the quadratic method.



**14. By extension of the Lill circle to include complex roots.**

The Lill Circle can also be used to find complex solutions. We have previously used  $x^2 - 2x + 5=0$  and I will use it again. We construct a vertical line on the axis of symmetry  $x = -b/2a = 1$ . Then we create a segment on the x-axis from  $(-1,0)$  to  $(c,0)$ . We cut an arc from the midpoint of this segment to cut the y-axis

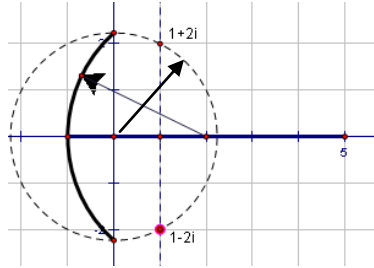

at a value that will be the square root of  $c$ . Now from a center at the origin, we draw a circle of radius  $\sqrt{c}$ , to cross the axis of symmetry in two places. These two intersections give us the complex solutions  $1+2i$ , and  $1-2i$ .

**15. Using the graph of  $y = x^2$  and  $y = -bx - c$  to find real roots.**

The modern graphing calculator has made finding the intersection of two curves remarkably easy, and every modern student should be exposed to this method. Rewriting  $x^2-3x-10=0$  as  $x^2 = 3x+10$ , we can graph both equations and, using the special functions available on most calculators, it will even find the intersection. But such a method

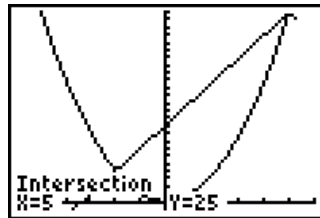

was not available when Professor Hazard made his list, and pursuing the solution by hand allows us to introduce another interesting property of parabolas that many students may not know. If you draw a line parallel to the x-axis at any value of  $y$ , it will intersect the curve  $y=x^2$  at  $x$ -values that are the positive and negative square roots of  $y$ . When the  $y$  value is 25, the  $x$ -value is 5 or  $-5$ , ect. Ok, Ok, that is almost *too* obvious, but now let's look at a similar property that exists for any line parallel to a tangent of  $y=x^2$ .

If we draw a tangent to  $y=x^2$  at any value of  $x$ , the slope is twice the value of  $x$ . At  $x=1$ , the tangent has a slope of 2, and at  $x=5$ , the tangent has a slope of ten. Any line parallel to this tangent that cuts the parabola will cut it with  $x$ -values that are more (and less) than the  $x$ -value of the tangent point by the square root of the differences in their  $y$ -intercepts. Ok, an example may help make that clear. Let's take the tangent at  $x=2$ ,  $y=4$  which has a slope of 4. It has the equation  $y=4(x-2)+4$  or  $y=4x-4$ . Now we will also graph the line  $y=4x$ , four units higher on the  $y$ -intercept. Since the square root of four is two, it will cut the curve  $y=x^2$  at  $x=4$  (two to the right of the  $x$ -value of the tangent) and at  $x=0$  (two to the left of the  $x$ -value of the tangent).

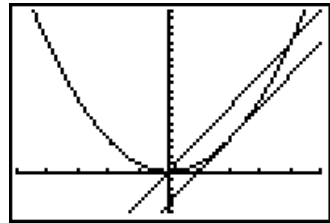

So how do we solve  $x^2=3x+10$ ? Well we know that the line with a slope of 3 will be tangent when  $x=1/2$  (3) and  $y=9/4$ . This equation is  $y=3(x-1/2)+9/4$  or  $y=3x-9/4$ . The line  $3x+10$  is  $49/4$  units higher than the tangent value of  $x=1/2$ ; so if we moved the tangent line up this distance, the  $x$  intercepts would be a distance of square root of  $49/4$  or  $7/2$  to each side of the  $x$ -value of the tangent. The solutions then will lie at  $x=3/2+7/2$  and at  $3/2-7/2$ . These are the two same solutions as before,  $x=5$  and  $x=-2$ .

### 16. By extending (15) to include complex roots

We can extend the method in 15 to solve complex solutions quite simply. I will use the example  $x^2-3x+8=0$ , rewritten as  $x^2=3x-8$  for illustration. The tangent line with a slope of 3 will be where  $x=3/2$  with an equation of  $y=3x-9/4$ . Since the graphs of  $x^2$  and  $3x-8$  do not intersect, we know the solutions are complex, and the real part of the solution is at  $x=-b/2a$  or  $3/2$ . If we were trying to find real solutions, we would ask how far up from the tangent line is the graph of  $3x-8$ , but in this

problem the line  $3x-8$  is below the tangent, so we need to move the tangent line  $-5\frac{3}{4}$  units to fall on the line  $3x-8$ . But if we try to use this distance in the way we used the positive values in the last method, we will decide that the solutions will be  $\pm\sqrt{\frac{-23}{4}}$  units away from the x-value of the tangent. This

gives the complex solutions of  $x = 1\frac{1}{2} \pm \frac{i\sqrt{23}}{2}$ .

A visual interpretation can be shown by rotating the graph of  $y=x^2$  around the point of tangency by  $180^\circ$  as shown here. The intersections occur at x-values that are a distance of  $\frac{\sqrt{23}}{2}$  right and left of the x-value of the point of tangency. The two arrows show the distances.

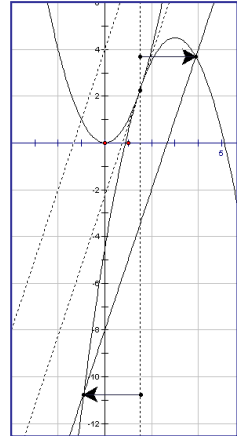

The same x-values can be found by reflecting the line  $y=3x-8$  about the tangent line to get  $y=3x+4$ . This line will intersect  $y=x^2$  at points that are the same distance from the point  $x=3/2$ .

**17. By use of a table of quarter squares.**

One of the earliest tools mathematicians of antiquities formed for themselves were tables of squares, cubes, multiples and reciprocals of numbers. A table of squares and a simple algebraic identity can be combined to offer another method of solving quadratics.

The identity is found by taking the square of the sum of two numbers,  $(p+q)^2$ , and subtracting from it the square of the difference of the two numbers,  $(p-q)^2$ . The difference in these two squared binomials gives four times the product of the two numbers  $p$  and  $q$ . Working from this we get  $\frac{1}{4} (p+q)^2 - \frac{1}{4} (p-q)^2 = pq$ . We notice that this equation contains the sum and

product of two numbers, and those have played a part in the solution of quadratic equations since antiquity. From this it is but a simple step to the solution of a quadratic.

As an example I will use  $x^2+4x-21=0$ , an equation we used earlier in a completing the square example (method four). From this we know the sum is  $-4$  and the product is  $-21$ . Letting  $p+q = -4$  and  $pq=-21$ , we can substitute into the identity above to get  $\frac{1}{4} (-4)^2 - \frac{1}{4} (p-q)^2 = -21$ . Some simple algebra leads us to  $\frac{1}{4} (p-q)^2 = 25$ , and  $p-q = 10$ . Now we know that  $p+q = -4$  and  $p-q = 10$ . Adding these two linear equations we get  $2p=6$ , and so  $p=3$  is one of the values; and letting  $p=3$  in  $p+q=-4$  yields the other solution,  $q=-7$ . The problem is easy to do with mental arithmetic, but had the problem been  $x^2+2.31x - 4.05=0$ , the computation might have been much harder if not for the availability of tables that told us the square of 231 and 405. The work was relieved even more by the use of tables of quarter-squares reducing the size of the values and minimizing the computations. They also allowed the multiplication of large numbers by the use of the tables. By simple addition and subtraction one could look up numbers in the table and multiply large values. J. Blater's *Table of Quarter-Squares of all whole numbers from 1 to 200,000* (1888), gave quarter-squares of numbers up to 200,000 and would allow the product of any two five-digit numbers.

The idea of finding a shortcut around more complex mathematical operations such as multiplication, powers, and root taking even had a name, prosthaphaeresis. The word is a combination of the Greek roots for addition, *prosth* and subtraction *aphaeresis*. Prior to the discovery of logarithms it was

very difficult to solve spherical triangle equations because it required several multiplications of sines and/or cosines to solve for a single unknown. Since most of these were represented as chords of a radius of  $10^5$ , or larger, it involved the equivalent of multiplying two five digit numbers together by hand for each multiplication. The identity above and tables of squares, or quarter-squares were one of these labor saving methods. In 1582, a Jesuit Priest named Christopher Clavius found another way. He showed how to employ a slightly different sum and difference in a trigonometric identity,  $\text{Cos}(A) \text{Cos}(B) = [\text{Cos}(A + B) + \text{Cos}(A - B)]/2$  to make faster work of such problems using only the tables of cosines. The method could be used to multiply any two numbers, but taking the arc-cosine of the number (divided by an appropriate power of ten). Here is how it might work for a simple problem. We will multiply  $314 \times 245$ . We express 314 as .314 and find that is the cosine of 71.6995 degrees. Doing the same with 245 we find  $\text{Cos}^{-1}(.245) = 75.8182$  degrees. Now we simply apply the identity above to show

$$\begin{aligned} \text{Cos}(A) \text{Cos}(B) &= [\text{Cos}(a + b) + \text{Cos}(a - b)]/2 \\ .314 * .215 &= [\text{Cos}(71.6995 + 75.8182) + \text{Cos}(71.6995 - 75.8182)]/2 \\ .314 * .215 &= [\text{Cos}(147.5177) + \text{Cos}(-4.1187)]/2 \\ .314 * .215 &= [-.843557 + 997417]/2 \\ .314 * .215 &= [.15386]/2 = .07693 \text{ and multiplying by } 10^6 \text{ to restore the correct magnitude to the original problem we see that this is } 76930, \text{ and } 314 * 215 = 76930. \end{aligned}$$

One of those who made very good use of the method of prosthaphaeresis was the Danish observer Tycho Brahe. Tycho tried to claim credit for the invention of the method, but we now believe he obtained the method from the itinerant mathematician Paul Wittich or the instrument-maker Jost Bürgi who may have been introduced to Clavius method during their travels. Bürgi is also noted for independently discovering the logarithm.

**18. By use of "Form Factors."** After several months of research I seem unable to find any where that Professor Hazard has written about this, and since he claimed to create the method, I'm sort of at a dead end. I am trying to contact a couple of guys at the University of Colorado to see if they can help. If this goes to print without an answer, and you are one of those rare people who know about this method, do please drop me a line.